

REVISIONS				
ZONE	REV	DESCRIPTION	DATE	APPROVED
	A	ECN 0839	28-SEP-22	

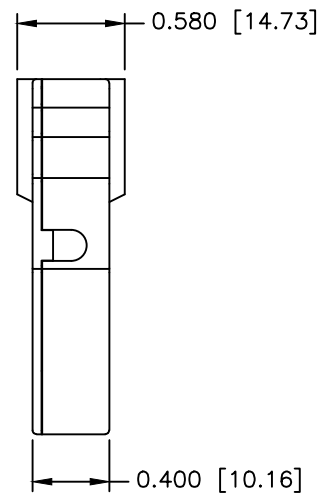
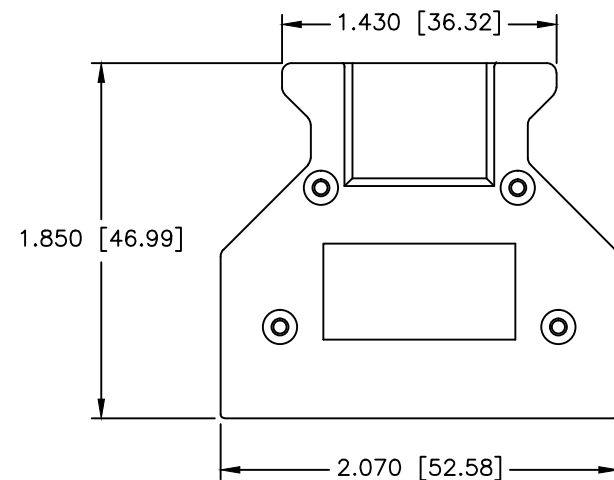
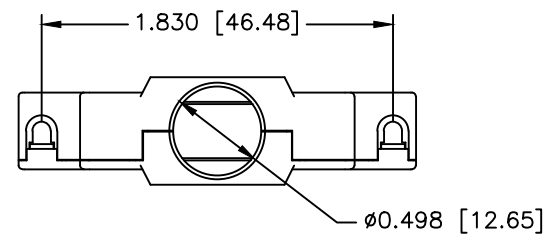

CONNECTOR COVER:

- 1.MATERIAL: ZINC ALLOY
- 2.FINISH: NICKEL PLATING PER NTC SPECIFICATION N/T 000400
- 3.DIMENSIONS: INCHES [MM]
- 4.TOLERANCE: ±0.015 [0.381]

COMPRESSION INSERT TREE

- 1.MATERIAL: THERMOPLASTIC PVC COMPOUND
- 2.COLOR: BLACK
- 3.DUROMETER: 75 ±5 TYPE A PER ASTM D2240
- 4.DIMENSIONS: INCHES [MM]
- 5.TOLERANCE: ±0.020 [0.508]

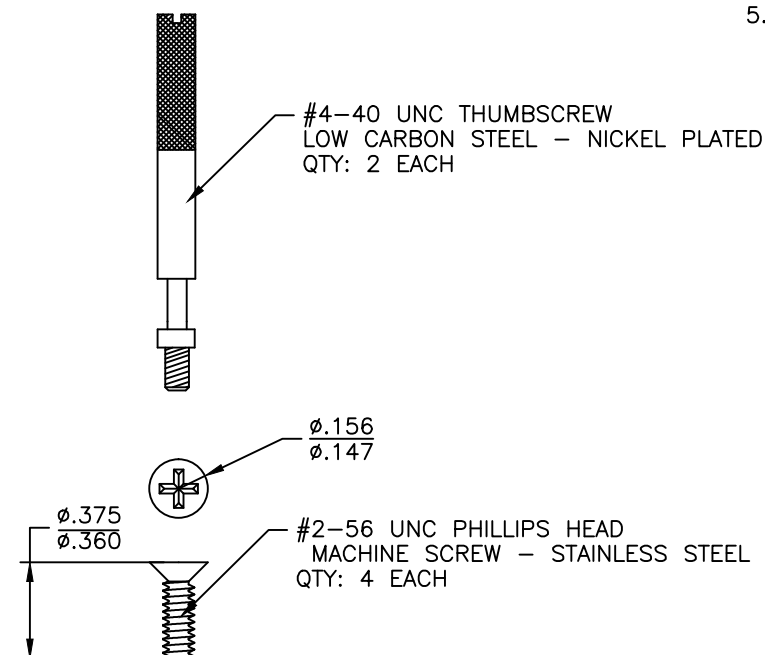
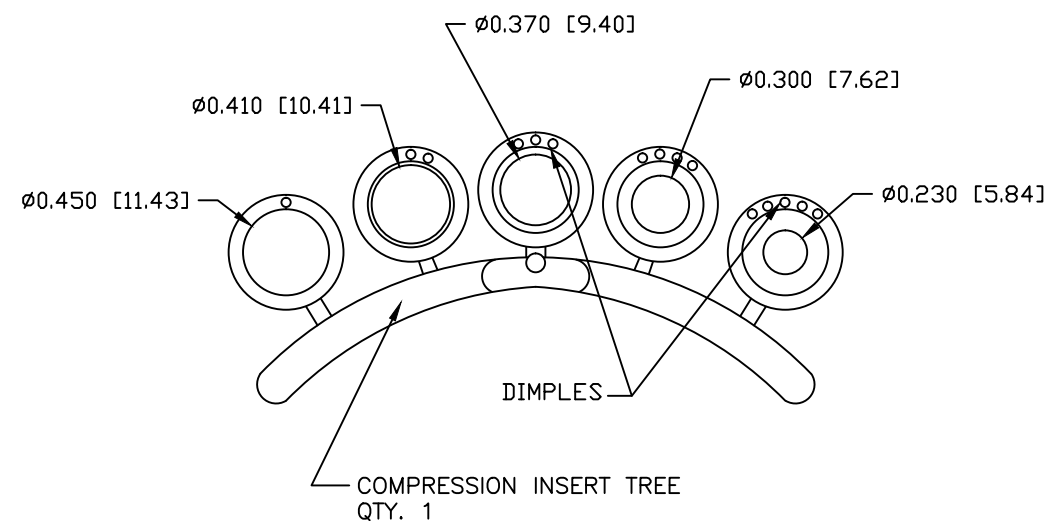

NO LOGO

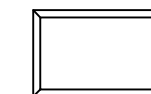

PART NUMBER INFORMATION

PART#	LOGO STYLE	SUPPLIED
NA90E110000T1	NO LOGO TOP COVER	BULK
NA90E110100	BOTTOM COVER	BULK
N90E110000T1	NO LOGO	PACKAGED

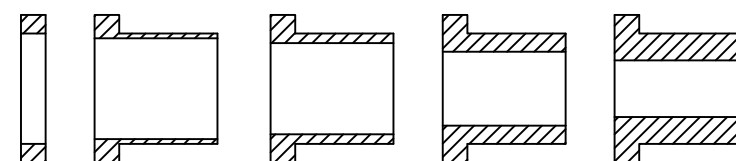

THIS IS A CONTROLLED DOCUMENT AND IS SUBJECT TO CHANGE. CONTACT NORTHERN TECHNOLOGIES ENGINEERING FOR THE LATEST REVISION.

UNLESS OTHERWISE SPECIFIED

1. ALL DIMENSIONS ARE IN INCHES (MM)
2. DIMENSIONS ARE TYPICAL

**Northern Technologies**

THIS DRAWING IS THE PROPERTY OF NORTHERN TECHNOLOGIES AND SHOULD NOT BE REPRODUCED WITHOUT NORTHERN TECHNOLOGIES WRITTEN PERMISSION.

PART NUMBER SEE PART NUMBER INFORMATION

DESCRIPTION CMHD 50 STR EXIT COVER W/THUMBSCREWS

DRAWN JSD	10-DEC-08	SIZE B	CODE 200_144T1	DWG NO. 0002-200-144T1	REV
CHECKED SCN	10-DEC-08	SCALE N.T.S.	SHEET 1 OF 1		
ISSUED	10-DEC-08				